

# Smart Systems Employing IoT Devices for Monitoring and Control of Electric Vehicle Residential Charging

Grant M. Fischer, Steven B. Poore, Rosemary E. Alden, Donovan D. Lewis, and Dan M. Ionel

SPARK Laboratory, Stanley and Karen Pigman College of Engineering, University of Kentucky, Lexington, KY, USA  
grant.fischer@uky.edu, stevenpoore@uky.edu, rosemary.alden@uky.edu, donovin.lewis@uky.edu, dan.ionel@ieee.org

**Abstract**—As the number of electric vehicles (EVs) on the road continues to increase, the rise in power demand may pose challenges, especially for the localized grid capacity during peak load events. This paper briefly reviews methods of power monitoring and load shedding such as smart charging and load management systems. An internet-of-things (IoT) power monitoring system is proposed for high-resolution power monitoring and control of J1772 standard level 2 EV charging systems to provide detailed data to enable future studies on EV grid integration. Additionally, a hardware test bench (HTB) including a DC battery emulator, oscilloscope, and commercial EV charger developed for experimental data collection of voltage and current is described. The systems may be applied, for example, to compare the capability of IoT smart systems to monitor EV charging at high resolution as a retrofit solution for previously deployed chargers without energy monitoring and control systems.

**Index Terms**—load shedding, J1772 level 2 charger, hardware test bench (HTB).

## I. INTRODUCTION

Electric vehicles (EVs) are rapidly growing in popularity with a 35% year-over-year increase in electric car sales and 14 million new electric cars on the road in 2023 [1]. Their impact on electric power usage is expected to increase as EV penetration increases in the United States, Europe, China, and across the world. The International Energy Agency forecasts EV charging to increase from just 0.5% of the world's current electricity demand up to 6-8% by 2035 [2]. This growth in electricity demand may require grid infrastructure to be altered to better address the growing number of EVs. The effect of increased EV usage will be felt the greatest during peak load times as people return home from work to charge their EVs and use other household appliances.

To help monitor and potentially stem the effects of increased EV electricity demand, especially during peak demand hours, smart charging systems can be utilized. Smart charging is the process of monitoring, managing, and optimizing the power draw of EV charging systems by varying the charging time and power level proportional to the availability and price of electricity based on user or utility set parameters [3]. Smart charging systems can be integrated into a wider smart grid of connected and integrated electrical systems where they will benefit both EV owners and electric utilities by sharing real-time information such as load uncertainty, electricity demand,

consumer preferences, electricity prices, and optimized charging strategies [4].

With the proper infrastructure in place, smart charging systems will have the capability to lower peak demand and EV carbon footprint by communicating with grid networks to prioritize renewable energy use, especially during off-peak hours, when green energy such as solar or wind energy is being produced [5]. As these smart systems continue to develop, they can utilize renewable energy forecasting and EV smart charging to optimize and schedule the charging of EVs based on forecasted renewable energy supply [6]. This would especially help take advantage of renewable generation such as wind and solar PV which can be easily altered by factors such as time of day, season, and weather. Smart network control services can help guide a cost-effective shift to EVs by managing and optimizing EV charging for the consumer while making it cheaper by controlling charge time and rate of charge so that future integration of EVs is easier for the consumer and the power grid [7].

A smart charging system is proposed that monitors the power draw of J1772 standard level 2 EV charging systems and controls the charger's output to the EV based on user-defined inputs. A hardware test bench (HTB) is also developed to emulate charging of an EV battery for collection of experimental voltage and current measurements. Additionally, smart charging and load management systems are analyzed to include a technology review for a variety of power monitoring and load shedding techniques for effective EV charging data collection and control.

## II. BRIEF TECHNOLOGY REVIEW

The growth in EV market penetration is resulting in an influx of research focusing on charging strategies to optimize operation and reduce the impact of EV charging on residential peak demand. Smart infrastructure designs, load management strategies, and internet-of-things (IoT) integrated grid management systems are areas of focus for optimizing EV charging in the present grid infrastructure. An overview is shown in Fig. 1 displaying a range of examples for these systems, and a review of the relevant technology and literature is included in this section.

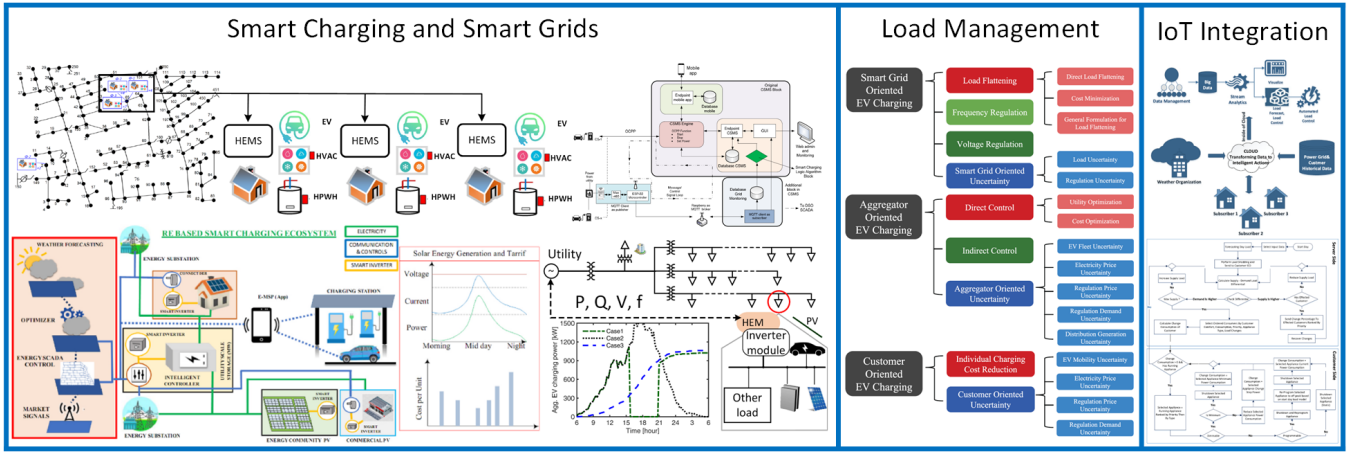

Fig. 1. Example smart infrastructure schematics, load management strategies, and IoT grid management systems for optimizing residential EV charging with a focus on renewable energy and smart grid integration based on concepts proposed, from top to bottom, left to right, by Poore *et al.* (2024), Barman *et al.* (2023), Riza *et al.* (2023), Gong *et al.* (2020), Wang *et al.* (2016), Mortaji *et al.* (2017).

Peak demand occurs due to coincident operation of high-power appliances on the grid, typically during evening hours for residential distribution systems. As EV ownership continues to increase, charging could further increase peak demand if left uncontrolled, due to EV owners charging their vehicles in the evening upon arrival from their daily commute. Another study by our group has proposed coordinated controls of EV charging with other high-power appliances to prevent residential transformer overloading during peak hours and reduce required infrastructure upgrades [8]. EV charging load could be shed before other high-power appliances to prioritize human comfort while still dispersing the residential area's load on hours with less demand. Three experimental EV charging power profiles from the Pecan Street dataset are displayed in Fig. 2, which in this case shows a peak demand from 3:00 to 8:00 PM [9].

Load management strategies are important to support consumer and utility needs during peak demand hours. A demand-side load management algorithm proposed by Keles *et al.* would meet power demand by shedding residential loads according to appliance priority based on user-defined and consumer-side appliance requirements reported by embedded smart meters [10]. Another study by Gong *et al.* proposes that smart home technology could be used to store surplus solar power generated during the day to schedule EV charging based on predicted solar power generation and EV predicted state of charge levels [11]. Both systems utilize smart technology to lower household power demand during peak hours. They could be integrated into a larger smart grid and paired with an IoT control network to lower demand for a larger residential area.

These monitoring networks could be tested by utilizing existing energy simulation tools like those that exist for high-power residential appliances such as water heaters, space heaters, and air conditioning units, which could also be equipped with smart metering systems [12]. A simulation platform and models described by Qiao *et al.* contribute to network planning, renewable power integration, and emerging

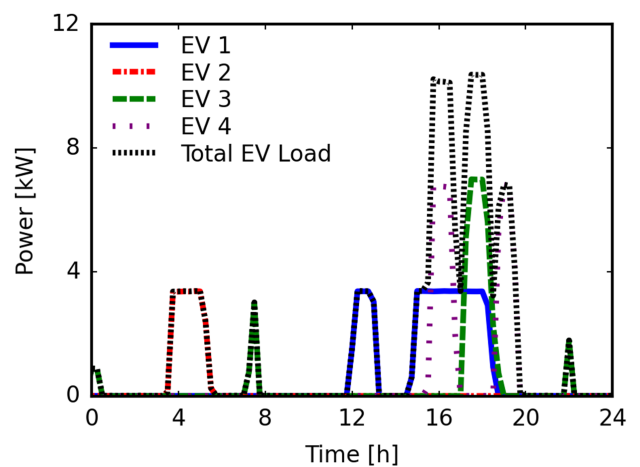

Fig. 2. Power demand of three EV charging units for a day in a residential area [9]. From 3:00 to 8:00 PM, the three charging units have overlapping charging periods causing the power demand to rise well above the average.

electric loads. Other examples include network, load profile, and EV charging models which are used to represent real-world systems [13].

An algorithm designed by Mortaji *et al.* utilizes IoT to communicate real-time analytics between consumer and utility meters for optimal smart grid controls including issue of shed commands and load forecasting [14]. This technology could be used to coordinate smart EV chargers to implement demand response and shift residential loads in time. Smart chargers can be controlled to operate during times when renewable generation is high or overnight when residential demand is low to minimize charging cost [15], [16]. Smart charging systems can be used in many ways such as controlling the power supplied to the EV by user-set schedules, integrating with a smart grid and operating with a wide range of inputs from both the utility and the EV owner, or monitoring the power draw of the EV without interrupting the charging process.

Smart charging systems require components that control power flow, monitor power use, and communicate with other

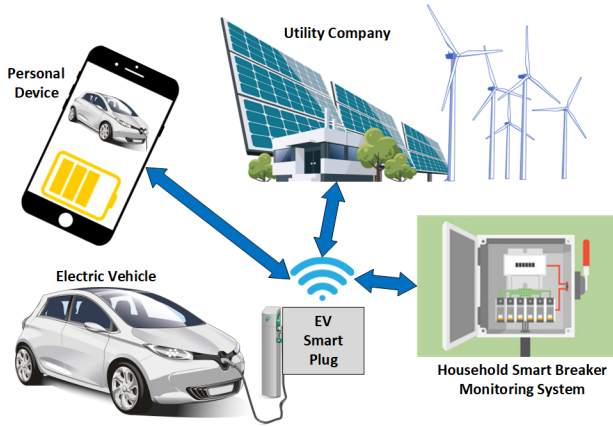

Fig. 3. Schematic representation of the proposed system integrated into the smart grid, communicating with other systems for EV charging monitoring and control.

devices to operate internal components based on external inputs. These systems can operate as smart plugs, designed to monitor the power between the outlet and the EV charger so that the system can be used for various residential charger models and can be integrated into smart home management networks. To minimize cost and increase accessibility, these systems can be built using Arduino Uno boards and other accessible components [17], [18]. Smart charging systems can be coupled with algorithms to optimize charging, execute load shedding while reducing charging time, and enable selective use of renewable generation [19]. This paper proposes a smart charging system utilizing the reviewed technologies for optimizing EV charging load management and providing data to enable future studies on EV grid integration.

### III. PROPOSED SYSTEM

The proposed open-source EV smart charger monitoring system is designed to monitor the voltage and current levels of J1772 standard level 2 EV charging systems and control operation given inputs from an external device. With these capabilities, the system could employ algorithms like those described in the technology review to optimize the EV charging process. The high-resolution power monitoring capabilities of this system could be utilized to provide detailed data for future power grid development to better incorporate the rise in EV ownership.

The open-source design is operated by an Arduino microcontroller and uses easily accessible components for the average residential EV owner. With this design, the microcontroller can be equipped with a WiFi module for connecting to smart home or smart grid networks as reviewed previously. The system would operate as an EV smart plug programmed to interact with personal devices, smart home monitoring systems, utility services, and more as depicted in Fig. 3.

Charging schedules could be determined based on the time an EV needs to be fully charged if the owner requires a fast charge time, peak load hours if the system prioritizes minimizing the risk of residential transformer overload and

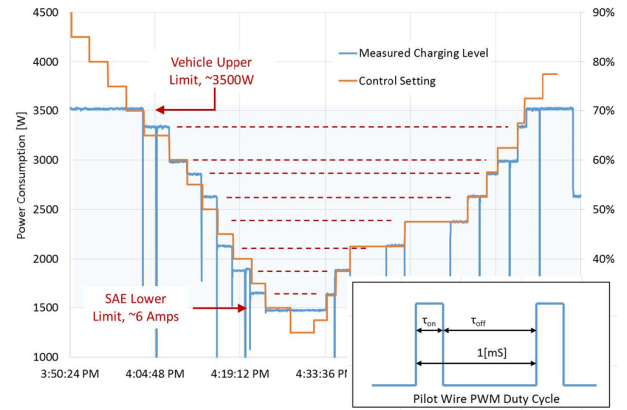

Fig. 4. Power draw of an EVSE in an experimental study adjusted through the PWM of the applied current and controlling the power flow between the upper and lower current limits of the EV [20].

the cost of charge, or a combination of these inputs. Other factors that could be considered once connected with external networks are utility load constraints, renewable energy generation, smart home IoT load requirements and preferences, and other relevant real-time or forecasted factors such as extreme weather events.

A report conducted by the Electric Power Research Institute (EPRI) studies EV supply equipment (EVSE) used to perform load shedding for EV charging [20]. In the report, the power draw of the EVSE was adjusted by controlling current through pulse width modulation (PWM) as seen in Fig. 4. High-speed solid-state relays or high-power transistors can be used to perform PWM. Adjusting the power draw of the EVs through PWM is an efficient way for open-source smart charging systems to control power output for dispersing the charging load over longer periods of time to ease the integration of EVs in the present grid infrastructure.

A schematic of the proposed system is illustrated in Fig. 5 with the primary components labeled. The system consists of two current transformers and a voltage transducer to obtain current and voltage measurements for monitoring power flow. A relay is included to control the power level of the charger. The microcontroller is connected to the voltage transducer, current transformers, and the relay to receive inputs from and control the internal components while interfacing with the external device to transmit live information and receive commands. It should be noted that the schematic includes NEMA 18-60 receptacles for lab testing while the real-world application would consist of the more common level 2 charger standard NEMA 14-50 receptacles. Future tests of this proposed system will be conducted on the laboratory hardware test bench.

### IV. EXAMPLE LABORATORY TEST BENCH AND DATA

A study of EV charging was conducted using a HTB developed for experimental data collection of voltage and current for monitoring the power flow between a single phase 208-240 VAC source and an emulated EV battery load. The schematic for this HTB is illustrated in Fig. 6 outlining the

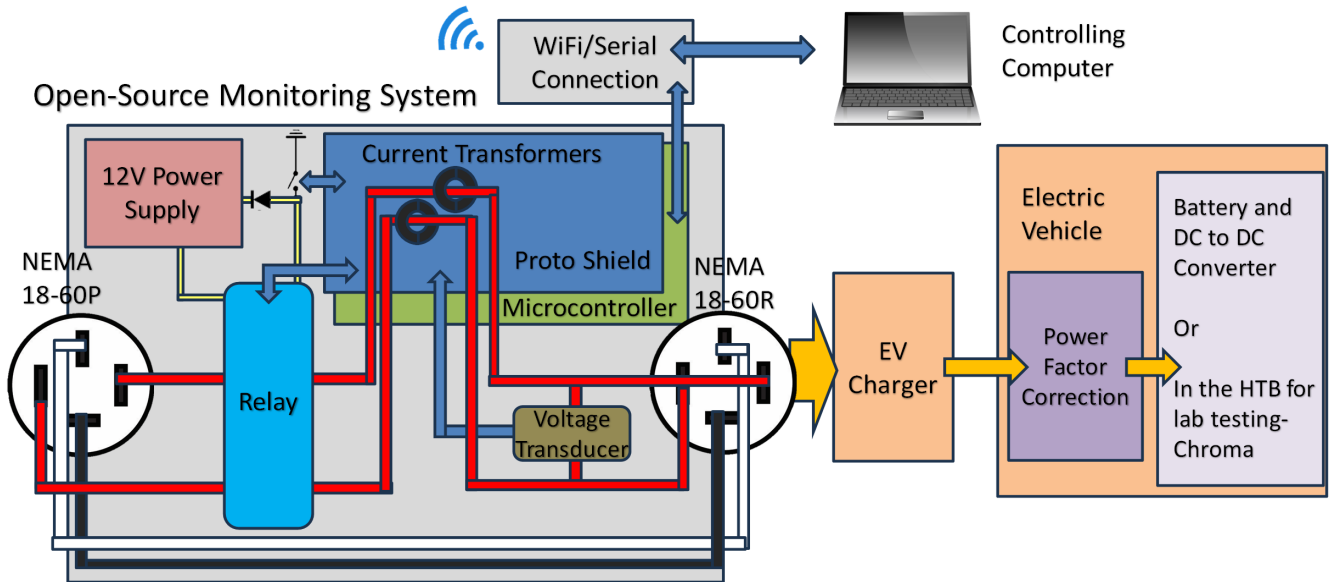

Fig. 5. Schematic of proposed open-source EV smart charger monitoring system. The red wires of the electric power system connect its relay, transformer, and transducer components. Blue arrows correspond to the flow of information between components and the microcontroller. PWM signal on the pilot wire to the vehicle.

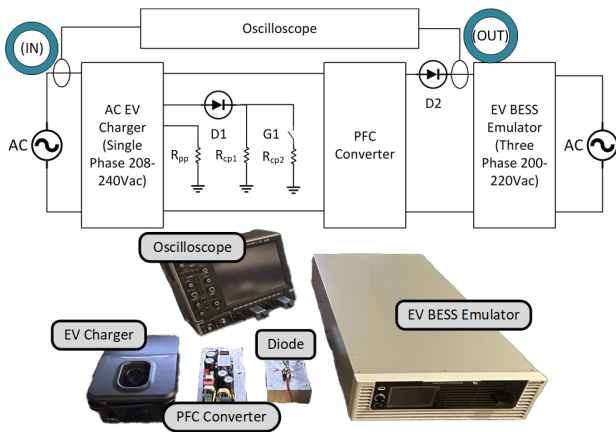

Fig. 6. Schematic of the hardware test bench (HTB) with photos of the components, illustrates the connections between the individual components of the system with nodes (IN) and (OUT) representing the input and output waveforms analyzed by the oscilloscope.

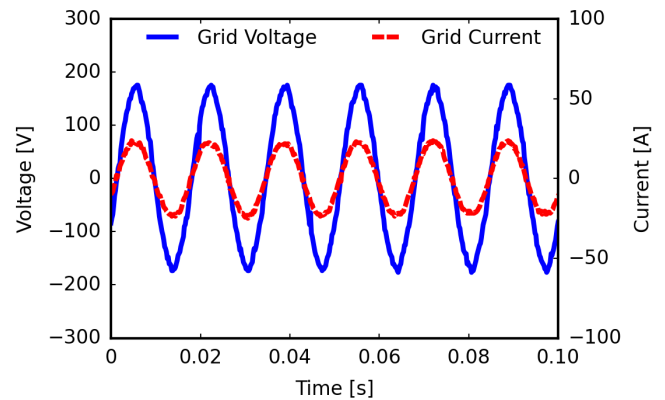

Fig. 7. Measured grid voltage and current for the input of the HTB at node (IN) from Fig. 6. The grid supplies AC power to the EV charger with near unity power factor.

components of the system. The HTB includes an EV charger powered by the single-phase source which is then connected to a converter with power factor correction (PFC). Since power electronics for signaling, conversion to DC, and PFC are typically included on-board in EVs, these components were added to the circuit to accurately model the EV charging process. The EV battery energy storage system (BESS) is emulated with a DC electronic load, and an oscilloscope is used to collect the voltage and current data for the input grid power at node (IN) and the output of the PFC converter to the BESS emulator at node (OUT).

Connectors of the J1772 type consist of two signaling pins, the proximity pilot (PP) and control pilot (CP). The PP signals the J1772 connector latch release to the vehicle control system.

This is a safety feature to prevent movement of the vehicle while connected to EVSE. The CP sends a signal from the vehicle to the EVSE to begin charging [21].

The CP signaling circuit, as shown in the schematic of Fig. 6, is typically in the vehicle inlet. This circuit was added to the HTB because, without it, the charger remains on “standby mode” without supplying AC power to the EV BESS emulator due to not receiving an activation signal from the vehicle. Switch G1 remains normally open, during which the charger remains in “standby mode” and does not supply AC power. When G1 is closed, another resistor is added in parallel between CP and ground, sending the “ready” signal to the charger which then supplies AC power.

The input AC grid voltage and current waveforms measured at node (IN) during the first test of the HTB are plotted



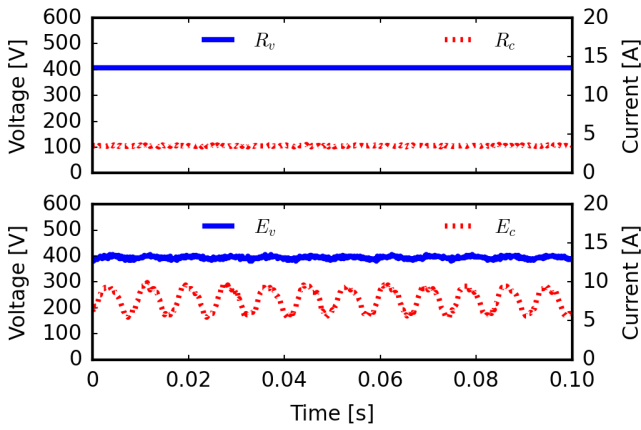

Fig. 8. Output voltage and current of HTB tests with different loads at node (OUT) from Fig. 6. Displays the minimal ripple of the DC voltage ( $R_v$ ) and current ( $R_c$ ) for the resistor test (top), and the ripple in the DC voltage ( $E_v$ ) and current ( $E_c$ ) for the EV battery emulator load test (bottom).

in Fig. 7. A resistor load test was conducted with a  $100\Omega$  resistor replacing the electronic load in the HTB schematic. The charging level for this test was  $1.6\text{kW}$ , which is lower than the HTB's charging capacity since the electronic load has a smaller resistance. The voltage and current waveforms measured at node (OUT) for the second test are shown in the top subplot of Fig. 8.

In a second test, the electronic load was set to  $3\text{kW}$  with the output voltage and current waveforms at node (OUT) shown in the bottom subplot in Fig. 8. The current magnitude is increased due to the higher power level in comparison to the resistor load test. The voltage and current waveforms of the electronic load test have negligible ripple in the voltage waveform and a ripple in the current waveform typical to the use of a state-of-the-art DC electronic load with regeneration output connected to the AC grid [22]. The voltage and current signals with the resistive load attached are a more accurate reflection of the flat waveforms expected for DC power.

The HTB can be used for future studies of EV charging, providing an adjustable environment for testing EV charging equipment and measuring voltage and current data. Together, the proposed EV charging monitoring system and the HTB can collect valuable data by running a wide range of charging tests such as the previously mentioned PWM and load-shedding charging control methods for EV grid integration.

## V. CONCLUSION

The proposed open-source EV smart charger monitoring system utilizes methods for optimizing residential J1772 standard level 2 chargers, such as smart infrastructure designs, load management strategies, and IoT grid management systems that were reviewed to promote EV integration in the present electric grid infrastructure. This system employs a relay, voltage transducer, microcontroller, and current transformers to monitor and control the power draw of residential EV chargers, while also having the capacity to utilize PWM

and a WiFi module for load shedding and smart network integration. The hardware test bench (HTB) was developed for experimental EV charging data collection. Development of the HTB, including the addition of an on-board signaling circuit establishing communication between the charger and emulated EV BESS load, serves as an example of a system providing high-resolution data for future studies benefiting continued research for EV charging.

## ACKNOWLEDGMENT

This paper is based upon work supported by the National Science Foundation (NSF) Graduate Research Fellowship Grant No. 2239063. The support of the Tennessee Valley Authority and University of Kentucky through the L. Stanley Pigman Chair in Power Endowment, the Lighthouse Beacon Foundation, and the E.On Scholarship in Power and Energy is also gratefully acknowledged. Any findings and conclusions expressed herein are those of the authors and do not necessarily reflect the views of the sponsor organizations.

## REFERENCES

- [1] International Energy Agency, "Global ev outlook 2024 trends in electric cars," 2024. [Online]. Available: <https://www.iea.org/reports/global-ev-outlook-2024/trends-in-electric-cars>
- [2] —, "Outlook for battery and energy demand," 2024. [Online]. Available: <https://www.iea.org/reports/global-ev-outlook-2024/outlook-for-battery-and-energy-demand>
- [3] Riza, Y. Margowadi, P. Aji, D. Priyasta, E. Rijanto, E. R. Priandana, F. Yusivar, and E. Nurdiana, "A design of smart charging architecture for battery electric vehicles," in *2023 IEEE PES Innovative Smart Grid Technologies Europe (ISGT EUROPE)*, 2023, pp. 1–5.
- [4] Q. Wang, X. Liu, J. Du, and F. Kong, "Smart charging for electric vehicles: A survey from the algorithmic perspective," *IEEE Communications Surveys & Tutorials*, vol. 18, no. 2, pp. 1500–1517, 2016.
- [5] P. Barman, L. Dutta, S. Bordoloi, A. Kalita, P. Buragohain, S. Bharali, and B. Azzopardi, "Renewable energy integration with electric vehicle technology: A review of the existing smart charging approaches," *Renewable and Sustainable Energy Reviews*, vol. 183, p. 113518, 2023. [Online]. Available: <https://www.sciencedirect.com/science/article/pii/S1364032123003751>
- [6] R. Fachrizal, D. Van Der Meer, and J. Munkhammar, "Direct forecast of solar irradiance for ev smart charging scheme to improve pv self-consumption at home," in *2021 IEEE PES Innovative Smart Grid Technologies Europe (ISGT Europe)*, 2021, pp. 1–5.
- [7] A. Goroumaru, Y. Endo, N. Takehiro, Y. Kawagoe, and D. Frenkel, "Promotion of ev shift by smart charging service," in *2020 9th International Conference on Renewable Energy Research and Application (ICRERA)*, 2020, pp. 457–460.
- [8] S. B. Poore, R. E. Alden, and D. M. Ionel, "Coordinated controls of residential ev chargers considering high power appliances," in *2024 IEEE Transportation Electrification Conference and Expo (ITEC)*, 2024, pp. 1–5.
- [9] Pecan Street Inc. Dataport, "Residential data," 2018. [Online]. Available: <https://www.pecanstreet.org/dataport/>
- [10] C. Keles, B. B. Alagoz, and A. Kaygusuz, "A note on demand side load management by maximum power limited load shedding algorithm for smart grids," in *2015 3rd International Istanbul Smart Grid Congress and Fair (ICSG)*, 2015, pp. 1–5.

- [11] H. Gong and D. M. Ionel, "Optimization of aggregated ev power in residential communities with smart homes," in *2020 IEEE Transportation Electrification Conference I& Expo (ITEC)*, 2020, pp. 779–782.
- [12] H. C. Anderson, A. Al Hadi, E. S. Jones, and D. M. Ionel, "Power factor and reactive power in us residences – survey and energyplus modeling," in *2021 10th International Conference on Renewable Energy Research and Application (ICRERA)*, 2021, pp. 418–422.
- [13] Z. Qiao and J. Yang, "Low-voltage distribution network re-configuration considering high penetration of electric vehicles x2014; a uk case study," in *2016 IEEE International Conference on Renewable Energy Research and Applications (ICRERA)*, 2016, pp. 708–713.
- [14] H. Mortaji, S. H. Ow, M. Moghavvemi, and H. A. F. Almurib, "Load shedding and smart-direct load control using internet of things in smart grid demand response management," *IEEE Transactions on Industry Applications*, vol. 53, no. 6, pp. 5155–5163, 2017.
- [15] S. M. De Oca, P. Monzón, and P. Belzarena, "Transactive energy for smart charge: Coordination of renewable generation and evs smart charging," in *2021 IEEE PES Innovative Smart Grid Technologies - Asia (ISGT Asia)*, 2021, pp. 1–5.
- [16] C. Lazaroiu and M. Roscia, "New approach for smart community grid through blockchain and smart charging infrastructure of evs," in *2019 8th International Conference on Renewable Energy Research and Applications (ICRERA)*, 2019, pp. 337–341.
- [17] R. E. Alden, P. Han, and D. M. Ionel, "Smart plug and circuit breaker technologies for residential buildings in the us," in *2019 8th International Conference on Renewable Energy Research and Applications (ICRERA)*, 2019, pp. 1018–1021.
- [18] S. I. Dukare, A. S. Bankar, P. S. Chobe, D. Pardeshi, and P. William, "Smart-charge-pro: Innovating energy metering and monitoring for sustainable ev stations," in *2023 4th International Conference on Smart Electronics and Communication (ICOSEC)*, 2023, pp. 119–123.
- [19] D. Wang, F. Locment, and M. Sechilariu, "Shedding and restoration algorithms for an ev charging station to maximize available power," in *2020 22nd European Conference on Power Electronics and Applications (EPE'20 ECCE Europe)*, 2020, pp. 1–9.
- [20] B. Seal, C. Thomas, "Performance test results: Cta-2045 electric vehicle supply equipment," 2017. [Online]. Available: <https://www.epri.com/research/products/000000003002011757>
- [21] R. Pratt, "Vehicle communications and charging control," *Pacific Northwest National Laboratory, Project ID# VSS142*, 2014.
- [22] Chroma, *Programmable Bidirectional DC Power Supply 62000D Series Operating and Programming Manual*.